

Ovládání : ruční pákou nebo převodovkou
pneupohonem
elektrickým servopohonem

Tabulka materiálů :

1	těleso	nerez ocel STM A315 GRCF8M uhlíková ocel ASTM A216 GR WCB / A516 GR 70
2	disk	nerez ocel ASTM A315 GRCF8M
3	hřídel	17-4 PH SS, ASTM A564 - type 630
4	kolík	17-4 PH SS, ASTM A564 - type 630
5	kroužek	nerez ocel, ASTM 276 AISI 316
6	pouzdro	nerez ocel AISI 316 s teflonovým těsněním
7	pouzdro	nerez ocel, ASTM 276 AISI 316
8	těsnění hřídele	PTFE + grafitový kroužek
9	kroužek	nerez ocel, ASTM 276 AISI 316
10	kroužek	18 - 8 nerez ocel
11	ucpávka	nerez ocel ASTM A315 GRCF8M uhlíková ocel ASTM A216 GR WCB / A516 GR 70
12	šroub	nerez ocel AISI 316
13	podložka	18 - 8 nerez ocel
14	mátice	18 - 8 nerez ocel
15	těsnící sedlo	RTFE nebo PTFE + pružná silikonová podložka
16	víko	nerez ocel STM A315 GRCF8M uhlíková ocel ASTM A216 GR WCB / A516 GR 70
17	šroub	18 - 8 nerez ocel
18	těsnění	PTFE + grafitový kroužek
19	zátku	nerez ocel AISI 316
20	lucerna	18 - 8 nerez ocel uhlíková ocel
21	šroub	18 - 8 nerez ocel
22	podložka	18 - 8 nerez ocel

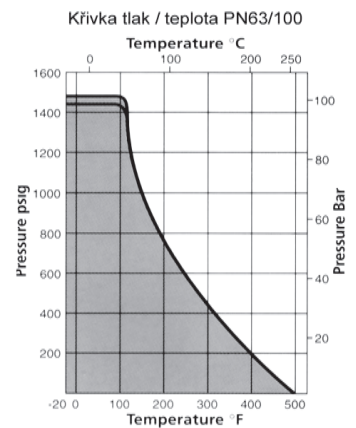
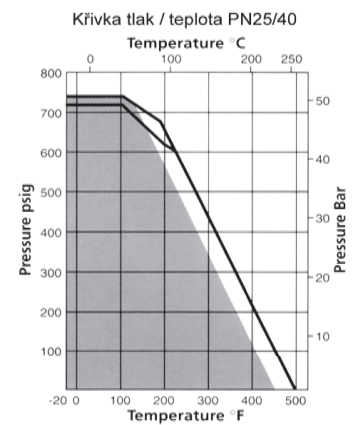
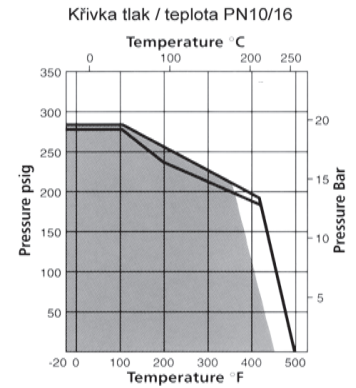

Systém těsnění

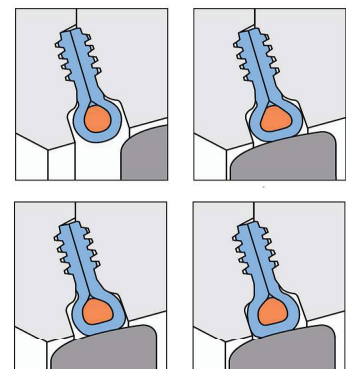

pokračování na další stránce

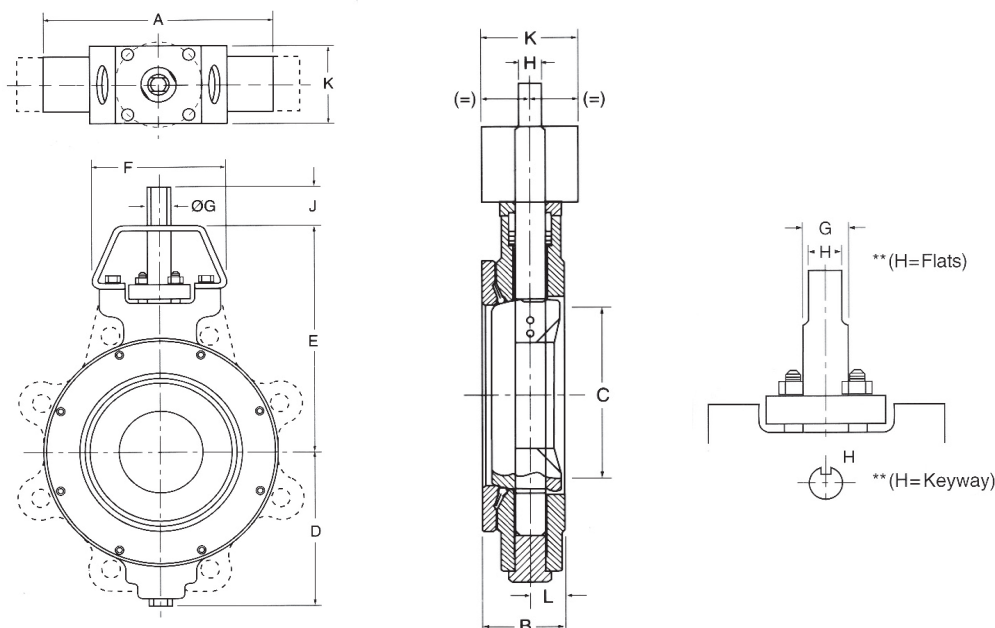

Tabulka rozměrů :
PN10/16 Serie 40

rozměry jsou uvedeny v mm

DN		A	B	C	D	E	F	ISO příruba			G	H	J	K	L
mm	ins							1	2	3					
65	2 1/2	121	48	58	97	162	111	70	4	10	16	11	32	64	20
80	3	133	48	73	104	168	111	70	4	10	16	11	32	64	20
100	4	171	52	94	120	191	111	70	4	10	16	11	32	64	19
125	5	191	57	122	129	191	130	70	4	10	19	13	32	114	24
150	6	219	57	149	141	203	130	70	4	10	19	13	32	114	24
200	8	273	61	198	176	241	130	125	4	14	22	16	32	114	24
250	10	332	70	248	217	273	155	125	4	14	30	22	51	114	27
300	12	394	78	298	259	311	155	125	4	14	30	22	51	114	29
350	14	445	95	328	304	368	197	125	4	14	35	10x10	51	165	36
400	16	503	104	373	329	451	264	165	4	21	50	12x10	64	165	42
450	18	544	117	422	359	508	264	165	4	21	50	12x10	64	165	47
500	20	601	128	470	388	578	264	165	4	21	64	16x16	102	165	52
600	24	711	152	572	463	635	391	254	8	17	76	19x19	102	298	62
650	26	749	165	568	488	635	391	254	8	17	76	19x19	102	298	71
700	28	823	165	672	522	679	391	254	8	17	76	19x19	133	298	71
750	30	876	191	719	543	730	495	298	8	21	89	22x16	133	343	79
800	32	956	191	767	568	762	495	298	8	21	89	22x16	133	343	82
850	34	1006	197	765	606	762	495	298	8	21	89	22x16	133	343	85
900	36	1033	210	864	642	838	495	298	8	21	89	22x16	133	343	92
1000	40	1295	241	940	692	940	495	298	8	21	114	25x19	133	343	111

PN25/40 Serie 42

DN	2	A	B	C	D	E	F	1	2	3	G	H	J	K	L
	1.11														
65	2	121	48	58	97	162	111	70	4	10	16	11	32	64	20
80	3	133	48	73	104	168	111	70	4	10	16	11	32	64	20
100	4	171	52	94	120	191	111	70	4	10	16	11	32	64	19
125	5	210	57	122	130	203	130	70	4	10	19	13	32	114	24
150	6	226	61	146	159	222	130	125	4	14	22	16	32	114	25
200	8	278	72	192	192	254	155	125	4	14	30	22	51	114	28
250	10	337	83	240	238	289	155	125	4	14	35	10x10	51	114	33
300	12	395	92	287	277	343	197	125	4	14	35	10x10	51	165	36
350	14	455	118	289	318	464	264	165	4	21	50	12x10	64	165	54
400	16	506	136	363	353	533	264	165	4	21	64	16x16	102	165	64
450	18	559	152	381	392	533	391	254	8	17	64	16x16	102	298	67
500	20	612	161	419	427	565	391	254	8	17	76	19x19	102	298	74
600	24	734	182	525	503	667	495	298	8	21	89	22x16	133	343	86
750	30	892	228	681	594	819	610	356	8	32	114	25x19	133	406	111